

SIPhoDiAS



Space-grade Opto-electronic Interfaces for Photonic Digital and Analogue Very-high- throughput Satellite payloads

Collaborative project
H2020-SPACE-2018
Grant agreement no: 870522

D3.4: 112 Gb/s transceiver module (public version)

Delivery Date:	31/12/2021 (M24)	Start date of project:	01/01/2020 (M01)
Date of submission:	28/02/2022	Duration:	36 months

LEAD PARTICIPANT FOR THIS DELIVERABLE			
Name:	ALTER-UK (Optocap)		
Contact Person:	S. Jones		
Address:	ALTER TECHNOLOGY TÜV NORD UK LTD (formerly Optocap Ltd) 5 Bain Square Livingston, EH54 7DQ UK		
Phone:	+44 (0)1506 403556	Fax:	
E-mail:	shaun.jones@uk.altertechnology.com		

Authors:	Shaun Jones, Anaelle Maho
Participants:	ALTER-UK, TAS

Work Package:	WP3		
Security:	PU	Nature:	P (prototype)
Version:	1.0	Number of Pages:	10

HISTORY OF CHANGES

ISSUE / SUBMISSION DATE	Page / section	Nature of change and reason
1.0 (28/02/2022)	-	-

TABLE OF CONTENTS

HISTORY OF CHANGES	2
TABLE OF CONTENTS	3
PURPOSE AND STRUCTURE OF THE DOCUMENT	4
1. DESCRIPTION.....	5
2. PRELIMINARY SPECIFICATIONS	5
2.1. Opto-electronic specifications.....	5
2.2. Environmental and mechanical specifications	6
2.3. Functional diagram.....	7
3. OTRx Module	8
4. Conclusion.....	9
LIST OF FIGURES	10
LIST OF TABLES	10

PURPOSE AND STRUCTURE OF THE DOCUMENT

This deliverable reports the high-speed optical transceiver module developed in H2020-SPACE-SIPHODIAS project by ALTER-UK. The deliverable is structured as a preliminary datasheet and presents the module specifications and the actual hardware implementation. The report is intended for public release.

1. DESCRIPTION

The optical transceiver (OTRx) developed by ALTER-UK in the frames of H2020-SPACE-SIPHODIAS project, is a high speed mid-board optics OTRx module applicable to intra-satellite high-speed serial links. The module deploys 4 transmit and 4 receive channels operating at 850 nm wavelength. The optical I/O is supplied through a standard MT connector interface. Electrical connection and pluggability on the host board is supplied through a MEC-5 COBO standardized connector.

The module specifications have been defined in collaboration with Thales Alenia Space (Toulouse) and are aligned with the requirements of digital photonic payloads that deploy high-speed optical interconnects.

2. PRELIMINARY SPECIFICATIONS

The specifications listed below are preliminary and will be updated following the completion of the module full functional test (FFT), which is in progress.

2.1. Opto-electronic specifications

Parameter	Symbol	Condition	Value			Unit	Notes
			Min	Typ.	Max		
Operating wavelength	λ	-	840	850	860	nm	
Signaling rate, each lane	SR	-		25.78125		GBd	NRZ per channel, in compliance to IEEE 802.3 100GBASE-SR4
Average launch optical power, each lane	Tx_avg	VCSEL I_bias 5 mA		+0.4		dBm	Each lane at 25 degC, BOL
Extinction ratio	ER	VCSEL I_bias 5 mA, I_mod 2 mA	3			dB	at 25 degC, BOL
Optical modulation amplitude	OMA	VCSEL I_bias 5mA ER 3 dB		-1.37		dBm	at 25 degC, BOL
Supply voltage	Vcc	-		3.3		V	
Transmitter power consumption	P_Tx	3.3 VDC		0.28		W	Total at 25 degC. BOL VCSEL I_bias 5mA
Receiver power consumption	P_Rx	3 VDC \pm 10%		0.43		W	Total at 25 degC. BOL PD V_bias 4.4 V.
Power efficiency				7.1		mW/Gb/s	
Differential input voltage swing	ΔV_{in-p}		200			mV	
Differential output voltage swing	ΔV_{o-pp}		400			mV	

2.2. Environmental and mechanical specifications

Parameter	Symbol	Target			Unit	Notes
		Min	Typ	Max		
Operating temperature	T _{op}	-40		+85	°C	
Storage temperature	T _{stg}	-40		+100	°C	
Electrical interface	-	MEC-5 connector				
Optical input interface	-	MT ferule				
Package size	LxWxH	39.4 x 17 x 7.2			mm	Without fiber pigtail and MEC-5 connector
Mass	-		6.4		g	Without fiber pigtail and MEC-5 connector

2.3. Functional diagram

With reference to the functional block diagram shown below, the OTRx module includes the following functional elements:

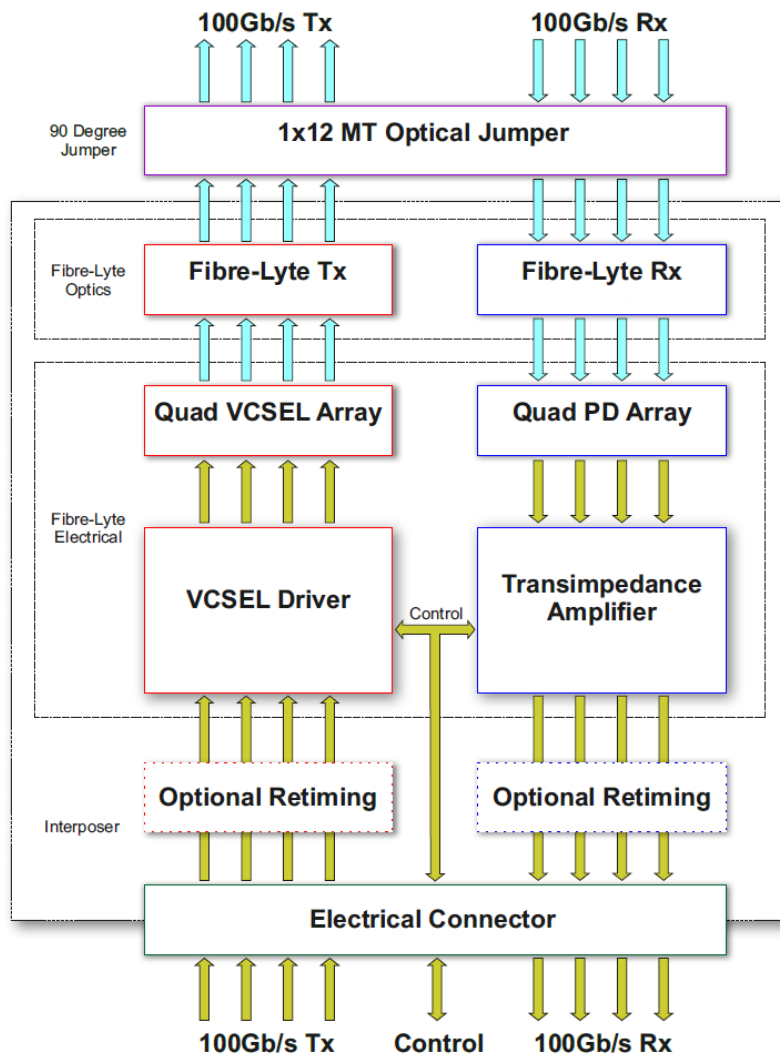

Figure 1: Functional diagram of the OTRx module: yellow arrows represent electrical connections and blue arrows represent optical connections. The functional diagram accommodates an optional re-timing electronic IC element.

- linear quad array of high speed 850 nm VCSELS
- linear quad array of high speed 850 nm PDs
- rad-hard VCSEL driver electronic IC
- rad-hard transimpedance amplifier (TIA) electronic IC
- serial Peripheral Interface (SPI) embedded in the VCSEL driver and TIA IC
- optional re-timing electronic IC depending on the modulation format and link budget requirements
- transparent carrier
- interposer PCB
- electrical connector interface
- optical interface including MT optical jumper and ribbon fiber array

3. OTRx Module

Figure 2 shows the fully assembled and packaged OTRx prototype without (top) and with (bottom) the MT ribbon fiber pigtail fitted.

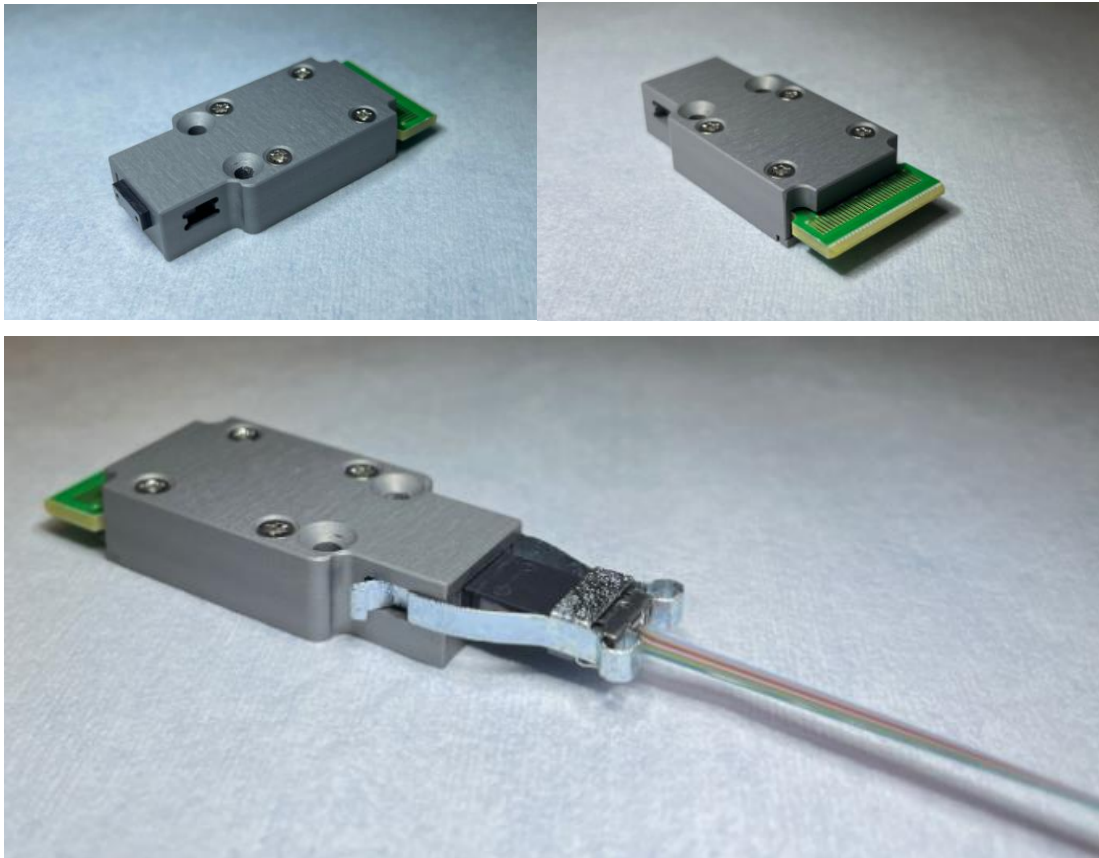

Figure 2 Packaged OTRx prototype by ALTER-UK.

4. Conclusion

This report has presented the high speed mid-board optics OTRx module developed by ALTER-UK in the frames of H2020-SIPHODIAS project. The information is intended for public release.

LIST OF FIGURES

Figure 1: Functional diagram of the OTRx module: yellow arrows represent electrical connections and blue arrows represent optical connections. The functional diagram accommodates an optional re-timing electronic IC element.	7
Figure 2 Packaged OTRx prototype by ALTER-UK.	8

LIST OF TABLES

No table of figures entries found.